



G.T.POWER®

# CONTAINER TRUCK LIGHTING AND VOICE VIBRATION SYSTEM PRO (US) **60A**



• Speaker • Vibration Motor • Lights • ESC

Thank you for purchasing the Container Truck Lighting and Voice Vibration System Pro (US) 60A. This unit integrates multiple effects into one, such as the ESC, lighting, sound, vibration and so on. You can set the working mode and control lighting switch by phone. It is easy to operate and can achieve perfect effect. Please read this entire operating manual completely and attentively before using.



Download on the App Store



GET IT ON Google Play



Scan the QR code to install the App of TRUCK L&S 60A

## Contents

1	Warnings and safety notes .....	01
2	Connecting diagram .....	01
3	Esc Description .....	03
4	Input channel .....	04
5	SBUS/PPM multi-channel control Fine tuning function ..	04
6	Output channel .....	04
7	Light control module .....	05
8	Restore factory default settings .....	07
9	Download App .....	07
10	SBUS/PPM setting .....	09
11	Remote controller calibration .....	10
12	Servo position calibration .....	13
13	Introduction of the remote controller special control ways .....	14
14	Rc Container Trailer Taillight System .....	16
15	Assembly description .....	16
16	Specifications .....	17
17	Product list included in the package .....	17
18	Warranty .....	18

## Warnings and safety notes

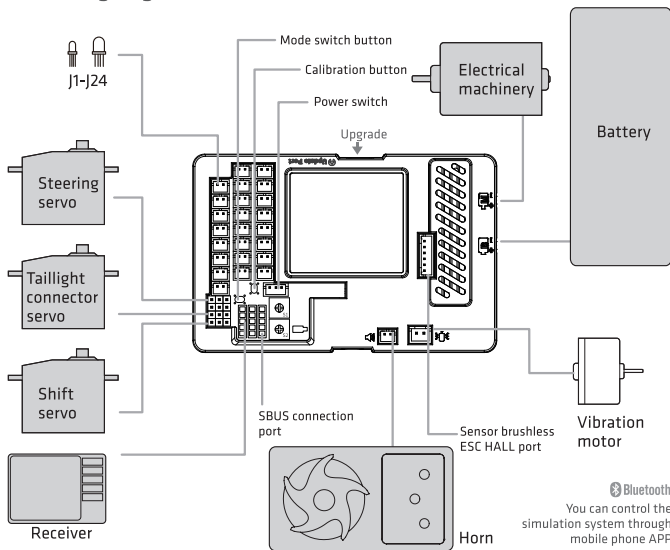

- Please connecting to the device and offer the power according to the manual
- Please ensure that no batteries connected before connecting or dis-connecting the device.
- Please set 4 digits pin for the device after you download the APP for safety consideration
- Please do not cover the surface of speaker vibration and place it to air ventilated place
- The speaker volume should be lowered to minimum to avoid damage before the unit first use or re-start use
- In order to make the sound effect to better, please do not put strong magnetic and interference items around the speakers.
- Please calibrate the remote controller before using to achieve a better effect.

## Connecting diagram



The remote controller which equipped with at least 4 Channels.

According to the diagram as below, connect the throttle motor, battery (2S/3S LiXX), horn, vibration motor, light cable, main control board, remote controller , receiver, steering servo, shift servo, etc.

<p><b>Power switch:</b></p>	<p>To control the whole sound unit.</p>
<p><b>Mode select:</b> (main board LED indicator indicate working mode, this function can set on your phone APP or you can choose it from the mode select key)</p>	<p>Simulation mode (all lights ON)-Manual mode(all lights ON) -ESC mode(light off),three light modes switch in turn. Power on is defaulted simulation mode, then press mode switch key to manual mode, press again to the esc mode.</p> <p>Simulation mode: all functions are available, blue indicator constantly light.</p> <p>Manual mode: Lights can only be operated by manual,blue indicator constantly light.</p> <p>ESC mode: the motor(not vibration motor) which with ESC output will run, indicator light off.</p>
<p><b>Light Switch:</b> (this function can use through your phone APP or controller)</p>	<p>Lights OFF- roof lamps -head lights - fog lamps in turn. Lights Off: All lights turned off; Roof lamps: Only roof lamp constantly light on Head Lights: roof lamp, head light constantly light on Fog lamps: roof lamp, head light and fog lamp constantly light on</p>
<p><b>HAZARD/Alarm switch:</b> (this function can use through your phone APP or controller)</p>	<p>When turn on the hazard lamp, left and right turn signal will flash and along with alarm sound,</p>
<p><b>SP.IND.ROOF switch:</b> (this function can use through your phone APP or controller)</p>	<p>If choose roof mode, 3 led light will turn on or turn off at the same time.</p> <p>If choose speed indicator mode and increase the throttle, then more lights will ON, show as below.</p> <div style="display: flex; justify-content: space-around; align-items: center;"> <div style="text-align: center;">  <p>Low gear</p> </div> <div style="text-align: center;">  <p>Second gear</p> </div> <div style="text-align: center;">  <p>Top gear</p> </div> </div>
<p><b>Volume knob:</b></p>	<p>Can adjust speaker volume through controller or phone APP. The default speaker volume value is 50%.</p>

## Esc Description

This product supports brush and brushless ESC, and supports maximum current is 60A. You can select brush and brushless ESC mode through phone APP. System defaulted mode is brushless ESC mode. After the two modes are switched, the system must be restarted to take effect

### Warnings

**You have to set the right mode when using brush and brushless ESC in case cause permanent damage to the machine.**

1. There are two lines B and C (yellow and green) for brush ESC using, and phase line A (blue) suspended.
2. When using brushless ESC, you can choose Hall mode or Hall-free mode in app. (Please note that Hall line has corresponding relationship with main line. If it cannot start up, you need to exchange the sequence of main lines. Among these six connection ways, only one way is right. Hall sensor only support 120 degree installation mode, and Hall power supply voltage is 4.9-7v).
3. You can set the maximum current of the ESC in app (according to the ESC actually supported current ).
4. The brushless ESC speed control mode can be set in app, including common mode and constant speed mode. The common mode is that output power is determined by the throttle position, and the constant speed mode is that output speed is determined by the throttle position ( Common mode is recommended).
5. It supports the angle setting in the no sense mode of brushless ESC, and the range is 0-30 degrees. The recommended angle is 25 degree. Users can fine tune the ESC according to the actual situation.

## Input channel (connected to remote controller):

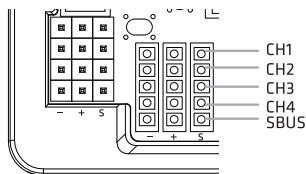

In order from top to bottom listed below, CH1, CH2, CH3, CH4; SBUS/PPM channel;

## SBUS / PPM multi-channel fine tuning control function

When the remote controller with more than 4 channels, other channels can be set another special function channel (set through the mobile phone app), no necessary to use complex operations such as fine-tuning.

Please note that the function channel set should be selected according to the remote controller's actual channel function (including 2-gear switch, 3-gear switch and potentiometer) ( For example, it is recommended to use potentiometer channel for volume control).

Please note that the channel signal priority is SBUS (up to 14 channels) > PPM (up to 8 channels) > PWM (4 channels). When recognized the high priority signal, the signal with inferior priority will automatically fail. SBUS is the fifth input channel (dedicated). PPM channel is the first channel input of the original PWM channel, and 1-4 channel are the original PWM channel input.

## Output channel (connected to servos and motors):

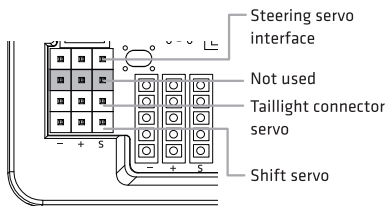

In order from top to bottom: Steering servo interface, not used, taillight connector servo, shift servo.

Remark: Near the left side is the negative pole (grounding), the middle is the positive pole, and the right side is the signal line.

## Light control module

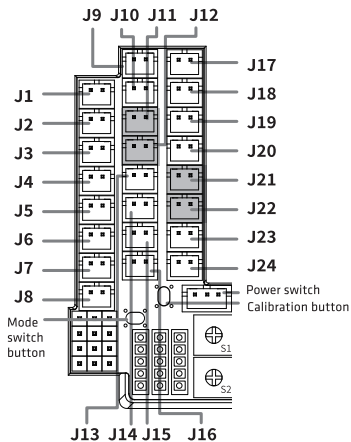

In light control module, you can choose auto, constantly light and constantly off three mode. Auto mode accepts controller control, constantly light and constantly off mode can not be controlled by controller.

 The color of the tube represents the color of the lamp.

J1-J3:	Speed indicator 1-3	Φ3	Yellow
J4:	Roof lamp	Φ3-Φ3	Yellow
J5:	Fog lamp	Φ5-Φ5	White
J6:	Tail turn signals(left) on the container	Φ3	Yellow
J7:	Tail turn signals(right) on the container	Φ3	Yellow
J8:	Coupler switch		
J9:	Brake light	Φ5-Φ5	Red
J10:	Reversing lamp	Φ3	White
J11/J12:	Is not used	*	*
J13:	Container trailer wireless taillight	Φ5-Φ5	Red
J14/J15:	Roof lamp2; roof lamp 1	Φ5-Φ5	White
J16:	Is not used	*	*
J17:	Front turn signals(right)	Φ3	Yellow
J18:	Rear turn signals(right)	Φ5	Yellow
J19:	Front turn signals(left)	Φ3	Yellow
J20:	Rear turn signals(left)	Φ5	Yellow
J21/J22:	Is not used	*	*
J23/J24:	Aux lamp/F Aux lamp/R	Φ3-Φ3	White

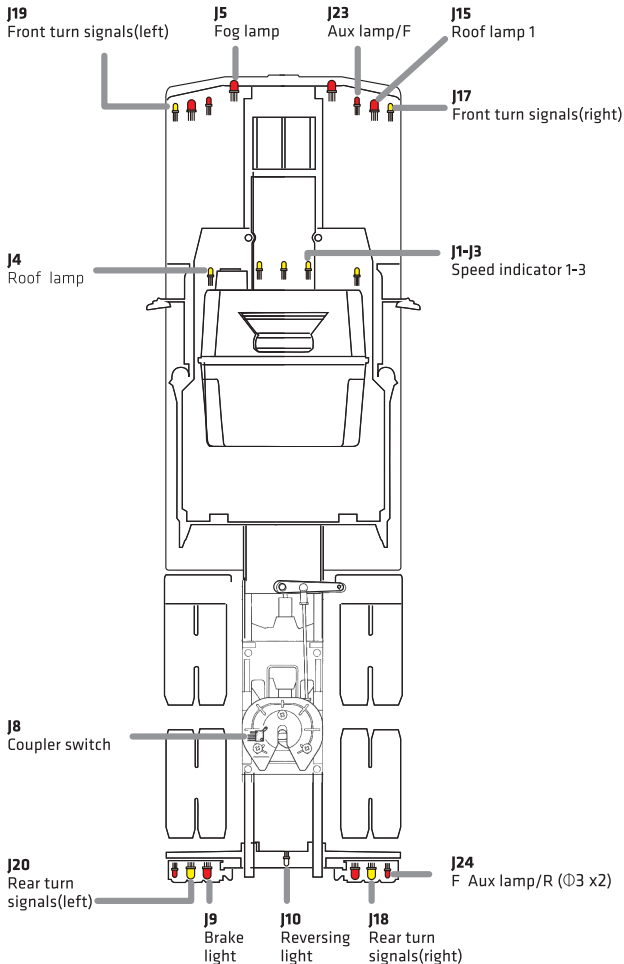



## Restore factory default settings

Hardware restore factory default settings: When power on 5-20 seconds, press and hold the two set buttons (calibration key and mode switch key) above 5 seconds. At this time, all the LED light rapidly flash, and the horn emits a rapid drip sound. Then release the button to restore the factory settings, including: remote control calibration info., servo position calibration info., phone APP settings, APP link password.

Mobile phone APP restore factory default settings: only restore the phone app settings, the rest are not restored.

## Download App

The product with Bluetooth module. You can use your phone to download its APP through connecting Bluetooth module. Through download the app (by scanning the QR code above), you can set relevant parameters on the app, control all modes and lights through app, and use the phone remote controller. Moreover, through app, it can avoid some specific functions that cannot be triggered due to the hardware difference of remote controller. It is easy to operate through phone, shown as below figure;

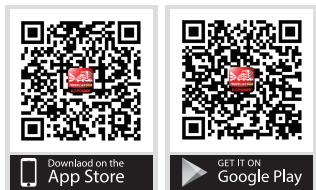

Scan the QR code to download APP.

### Notes:

Due to the mobile phone can directly control the vehicle, for safety, you need to set a 4-digit word password when connect your phone with app. If the password is not modified, it only needs to enter the password once for the same phone. If you forget the password, use the main board to restore the factory settings, and no password by default.

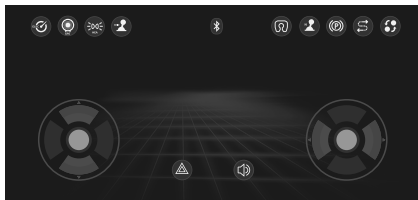

Open the setting interface and select the "remote control" option to open the phone remote control, functions show as below.

**Roof lamp/ speed indicator switch:**

Please refer to the introduction of roof lamp switch.

**Brake:**

parking in place

**Mode switch:**

switch between simulation mode and ESC mode

**Steering gear direction adjustment:**

steering gear reverse adjustment

**Light switch:**

off - roof lamp - head lamp - fog lamp switch.

**phone remote control handle direction switch:**

the direction of the lower remote control handle is adjusted vertically, that is, the horizontal direction changes to the vertical direction

**Coupler switch:**

separate coupler and container

**Alarm:**

turn on the danger alarm lamp (left and right turn signal double flashing) and alarm sound

**Neutral gear:**

neutral in place

**Horn:**

turn on or off the sound of the siren

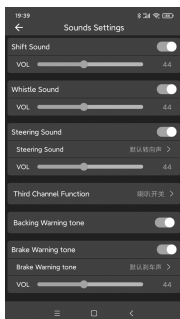
**• The third channel function:**

Through the third channel on the remote controller, you can select the function of the horn switch or the function of the Coupler switch.

Remote controller input error alarm: When the remote controller input error, the horn will alarm, and the APP home page will appear the alarm signal.



### • Low voltage protection:

If turn on this function, system will shut down when each cell voltage lower than 3.3V.

ESC reverse setting: The Esc can be set forward or reverse to control the motor.

You can use the above settings to match a set of satisfying sound and lighting effect.

### • Automatic start/stop:

When you start this system, if the throttle is in the middle position, the vehicle is stationary and the engine is idle, if you turn on the automatic start/stop system, the engine will self-extinguish after a delay according to the time you set (5S-60S). The engine will only restart when you touch the throttle again. You can choose shut down the automatic start/stop system, in this situation, at any state, as long as the engine has started, the voice system will be working all the time.

Starting sensitivity: Through start sensitivity (0-100) for rapid or normal starting engine.

ESC neutral switch: When the function is turned on, the vehicle will not move forward. The function can be used to set relevant modes. When the function is turned off, the vehicle can move forward normally.

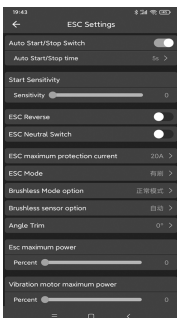

## SBUS/PPM setting

The remote control supports the SBUS function, when with more channels, you can set including the main volume adjustment, the ESC force adjustment, the vibration intensity adjustment, the double flash lamp (alarm signal), the light control mode, stall the car in place, the ESC neutral -gear switch, the third channel coupler /horn switch, the turn sound switch, the roof lamp/ speed indicator mode switch, the main mode selection , brushless ESC sensor/sensorless switch, brushless ESC the common mode / constant speed mode switch, manual air venting, Horn toggle.

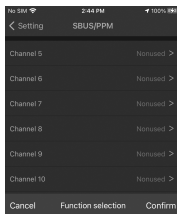

- **Vibration regulation:**

Adjust the speed of vibration motor

- **ESC force regulation:**

Adjust the ESC force, that is, to adjust the output capacity of ESC.

## Remote controller calibration

Note: When using this product for the first time, you need to use the remote controller to calibrate the product. The calibration steps are as follows (take left throttle controller as an example):

Each channel calibrates in turn, from Neutral position to the maximum position and then to the minimum position. You will hear a short beep when calibration finished, and hear a long beep when each channel calibration finished. You will hear 3 short beeps when calibration fails. It

will exit automatically when calibration is completed.

(The System default setting is, channel 1 and 4 to the right for the maximum value, left for the minimum value, channel 2 and 3 up for the maximum value, down for the minimum value, if you set the position value by yourself, adjust by yourself when calibration)

The following is the calibration diagram (taking below channel calibration as an example):

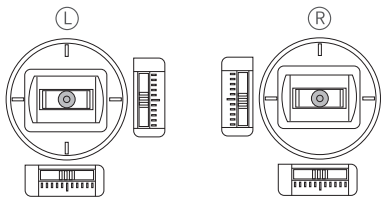

1. Long press the calibration button, after one beep sound, confirm the direction channel (the first channel) in neutral position, press the calibration button to calibrate till hear one beep.

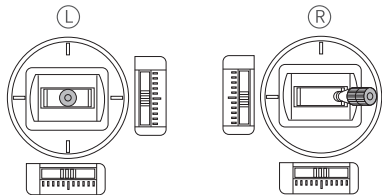

2. Move the direction channel (the first channel) to the maximum position, press calibration button till hear one beep

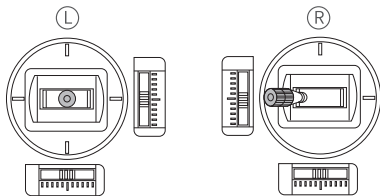

3 Move the direction channel (the first channel )to the minimum position, press calibration button till hear one beep

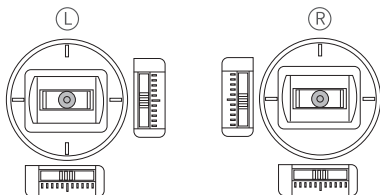

4. confirm the throttle channel (the second channel )in neutral position , press the calibration button to calibrate till hear one beep .

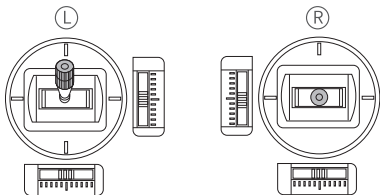

5. Move the throttle channel (the second channel )to the maximum position, press calibration button till hear one beep

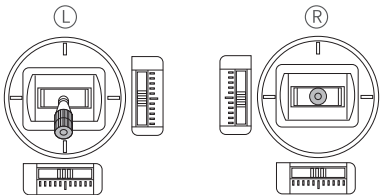

6 Move the throttle channel (the second channel )to the minimum position, press calibration button till hear one beep

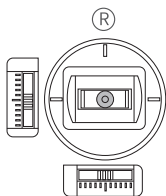
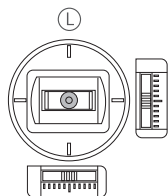

7. Confirm the third channel in neutral position , press the calibration button to calibrate till hear one beep .

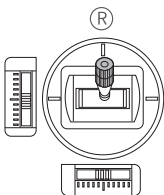
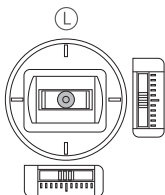

8. Move the third channel to the maximum position, press calibration button till hear one beep

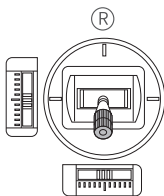
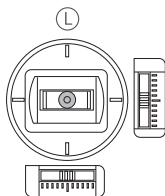

9 Move the third channel to the minimum position, press calibration button till hear one beep

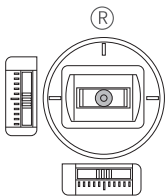
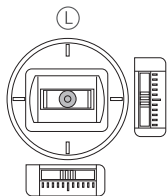

10. Confirm the the fourth channel in neutral position, press the calibration button to calibrate till hear one beep.

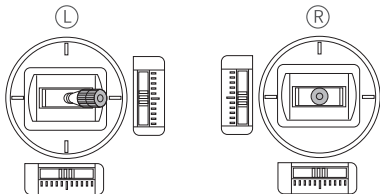

11. Move the fourth channel to the maximum position, press calibration button till hear one beep

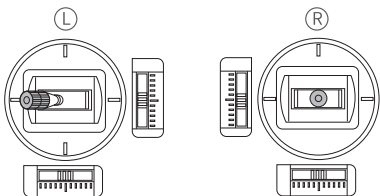

12. Move the fourth channel to the minimum position, press calibration button till hear one beep, then you will hear a long beep, the whole channel calibration is completed. You will hear 3 short beep when calibration failure, and you need re-calibrate.

### Servo position calibration:

Disconnect the power supply, keep the first channel and the third channel maximum power on, and enter into the servo position calibration mode.

Put the steering and shifting servo plugged into the circuit board to control S1 and S2 respectively. It can control the position of the shift servo and steering servo. Adjust the position of the two servo to the best, and then press the calibration button. It will beep one time after success, and it will beep three times after calibration failure. Calibration of the position of

the two servo is divided into three steps: 1. move S1 and S2 to let the servo to the neutral position, press the calibration button; 2. move S1 and S2 to let the servo channel to its maximum position and press the calibration button; 3. move S1 and S2 to let the servo channel to the minimum position and press the calibration button till calibration is completed;

## Introduction of the remote controller special control ways

### 1. Light selection mode

Slightly move down the third channel of the remote controller transmitter to the end, then move down the third channel of the remote controller to turn on the roof lamps, head lights, fog lamps successively till turn off the light.

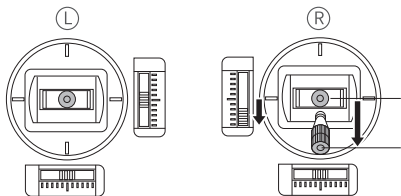

### 2. Hazard warning lamp on and off

Slightly move up the third channel of the remote controller transmitter to the end, then move up the third channel of the remote controller to the end to turn on or turn off the hazard warning lamp (Left and right turn lights flash at the same time).

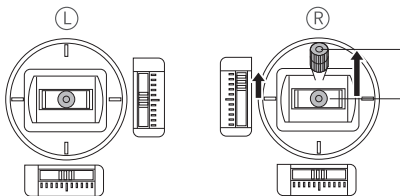

### 3. Neutral mode

Slightly turn the 4th channel of remote controller transmitter to the left end, then turn the 4th channel of remote controller to the left end to turn on or turn off the neutral mode.

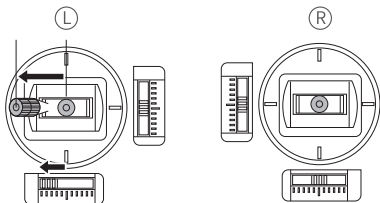



#### 4. Switch the coupler and horn

Slightly turn the 4th channel of remote controller transmitter to the right end, then turn the 4th channel of remote controller to the right end to switch the third channel function, that is to switch the coupler and horn.

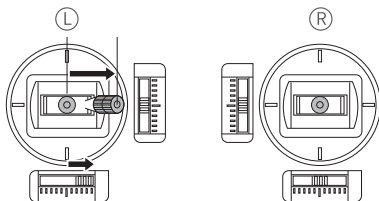

#### 5. Stall the car

Slightly turn the 4th channel of remote controller transmitter to the right end, and slightly move up the third channel to the end, then turn the 4th channel to the right end and move up the third channel to the end to stall the car. If need to re-start up, you can do it again, turn the third channel of the remote control to the bottom to start up or restart after power off.

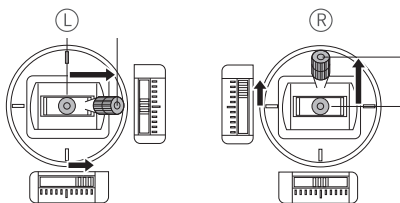

#### 6. Steering sound switch

Slightly turn the first channel left to the bottom and the third channel down to the bottom, that is, when the remote control handler turn to the left corner can switch the steering sound.

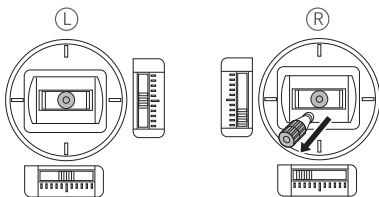

#### 7. Manual air venting

Turn the third channel to the bottom, then turn the second channel (throttle) down will trigger air venting.

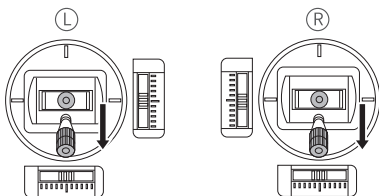

## Rc Container Trailer Taillight System(optional)

This system can work with G.T. RC container trailer taillight system, it use infrared wireless tech., easy to operate.

### Operation Instructions :

As show on the image, connect infrared transmitter port to the original brake light position (Container Truck Lighting and Voice Vibration System Pro(60A)-J13), the new brake light connect to the taillight brake light position.

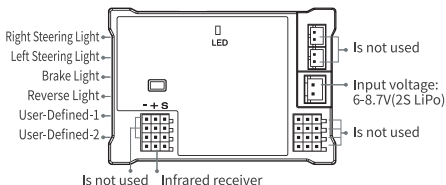

### Pairing:

1. Power on the PCB of taillight, and the blue LED is constantly light. It must be paired for first time using. Here is the pairing method: Consistently press button of taillight and blue LED will blink, and then plug into the infrared transmitter of Container Truck Light&Sound System Pro, and align it with the infrared

receiver. Please keep the distance as close as possible.

2. Power on the Container Truck Light&Sound System Pro. Wait for several seconds, it complete pairing when the blue LED of taillight is constantly light. If it needs to replace the main board or the control board of taillight, it requires to pair again.

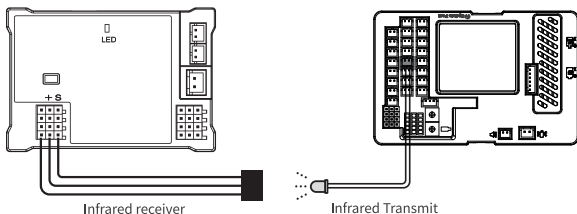

### Assembly description:

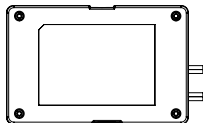

- 1 Wipe clean the bottom of the main control box, control board and horn before installing it. Use the 3M sticker sticks to the right place on your car (different brands and different styles of cars can be applied), or use your own adhesive.

- 2 The vibrating motor will be fixed with four PA3.5\*8 screws, (It is suggested to use screw glue for auxiliary fixation when installing the vibration module) due to the large vibration, you have to fix it well in case of any accidents.

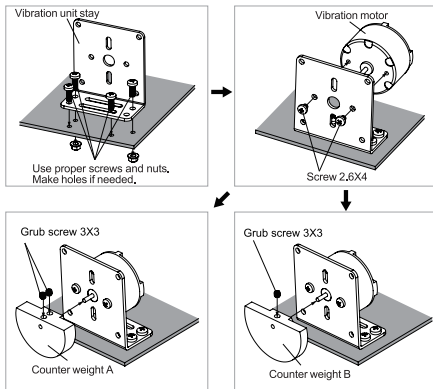
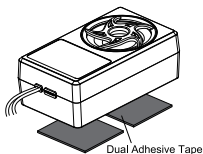

- 3 Sound effect will be affected by the mounting surface material and size, we propose you to choose a appropriate location to install the horn.

## Specifications:

Operating voltage range:	DC 7-14V;
Maximum working current for each light pack:	30mA;
Speaker:	Inner resistance 4Ω, Power ≥ 10W
Remote controller:	More than 4 channels
ESC current:	Max 60A;

## Product list included in the package:

Main control box:	1pc
Vibration motor:	1pc
Vibration module:	2pc
Speaker :	1pc
Light lines:	1set
Operating manual:	1set
Accessories:	1set

## Warranty

We warrants this product for a period of one year (12 months) from the date of purchase. This guarantee covers any material or design defects that are present in the product at the time of purchasing. During that period, we will repair or replace free of charge any unit that is determined to have failed as a result of those causes. The warranty does not cover failure as a result of wear, misuse, use of incorrect accessories or a failure to fully follow the guidelines in this instruction manual. You will be required to present a proof of purchase in order to make a warranty claim. The warranty is valid for the original purchaser of this unit only and is not transferable.

# 专业版货柜车声光系统(美版) **60A**



- 喇叭
- 震动电机
- 灯线
- 电调

感谢您购买本公司的专业版货柜车声光系统(美版)60A, 该系统集合电调、灯光、声音、震动等效果一体, 还可通过手机设置工作模式、设置混控多功能, 控制灯光开关、手机遥控等相关功能, 操作简单、功能多样化, 而且可以轻松避免遥控器硬件区别导致出现的诸多问题, 让其装饰您的爱车, 犹如灵魂附体, 蓬荜生辉。使用产品之前请仔细阅读本说明书, 我们在编写说明书时尽力使用大家熟悉的名称让初学者读起来轻松易懂。

**Bluetooth**



Download on the  
App Store



GET IT ON  
Google Play

扫描二维码安装货柜车声光系统高端版APP

# 目 录

1	注意事项	21
2	接线说明图	21
3	电调说明	23
4	输入通道	24
5	SBUS/PPM多通道控制	24
6	输出通道	24
7	灯光控制模块	25
8	恢复出厂设置	27
9	下载APP	27
10	SBUS/PPM设置	29
11	遥控器校准	30
12	舵机位置校准	33
13	遥控器特殊控制方式介绍	33
14	货柜无线尾灯系统	36
15	装配说明	36
16	参数	37
17	产品清单	37
18	保修说明	37



## 注意事项

- 严格按照说明书接线图，进行连接安装以及供电，并确保其安装稳固安全。
- 请注意连接或者断开设备时需时刻记住要断开电池，确保安全。
- 请下载APP后，为了安全考虑，一定要设置4位数设备密码。
- 音箱振动膜上方严禁有其他物体遮挡，并注意音箱应该安装在通风散热好的地方。
- 第一次启动或者重新设置安装启动前都需要将音箱音量调至最低，然后启动，避免损坏音箱。
- 为了使仿真效果更好，请不要将有强磁性以及干扰强的物品放在音箱周围。
- 在更换遥控器或者第一次使用该产品时，都必须对遥控器进行产品校准达到理想效果。

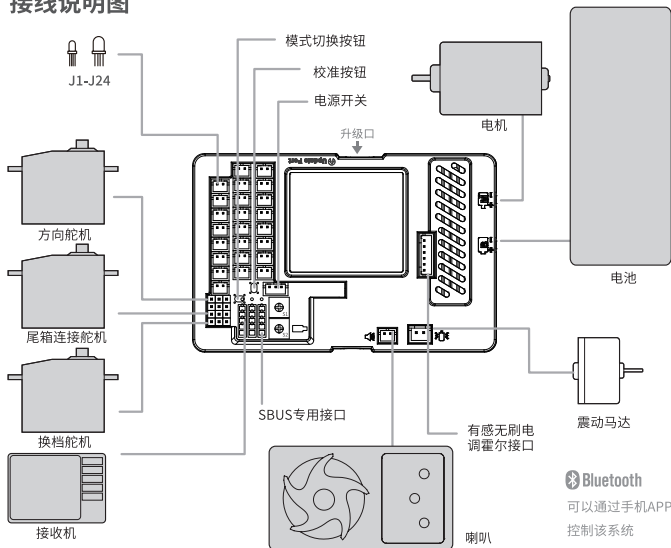
## 接线说明图



使用本产品至少需要4个通道的遥控器。按照示意图,接入电机(油门马达)、电池(2S/3S LiXX)、喇叭、震动马达、灯线、主控板、遥控器接收机、方向舵机、换挡舵机等。

<p><b>电源开关:</b></p>	<p>控制整个系统的总开关</p>
<p><b>系统工作模式:</b> (控制板LED灯指示对应工作模式),该功能可以通过手机APP进行设置,也可以通过主板上模式切换按键进行选择</p>	<p>仿真模式(灯常亮)-&gt;手动模式(灯常亮)-&gt;电调模式(灯不亮)三种模式按固定时间轮流切换,重新上电即默认为仿真模式,然后按下模式切换键就变为手动模式,在按下就变成电调模式,依次循环。</p> <p>仿真模式:全部功能都具备,系统蓝色指示灯常亮 手动模式:只能手动操作灯光亮灭,系统蓝色指示灯常亮。 电调模式:只有电调输出的马达(非振动马达)有转动,系统指示灯不亮。</p>
<p><b>灯光模式切换:</b> (该功能可以通过遥控器切换或者手机APP切换)</p>	<p>关闭-&gt;顶灯-&gt;大灯-&gt;雾灯,三种灯的状态轮流切换 关闭:所有灯光都关闭 顶灯:顶灯位置下只有顶灯常亮 大灯:大灯位置下顶灯、大灯都常亮 雾灯:雾灯位置下顶灯、大灯、雾灯都常亮</p>
<p><b>危险报警指示开关:</b> (该功能可以通过遥控器切换或者手机APP切换)</p>	<p>打开双闪会出现左右转向灯都闪烁(危险报警闪光灯),并伴随提示音。</p>
<p><b>顶灯指示灯功能切换开关:</b> (该功能可以通过遥控器切换或者手机APP切换)</p>	<p>选择顶灯模式功能,则顶灯3个LED同亮或者同时灭。 选择速度指示功能,则顶灯LED则会随着马达的输出即油门的增加,LED亮的越多,如下图</p> <div style="display: flex; justify-content: space-around; align-items: center;"> <div style="text-align: center;">  <p>低速前进</p> </div> <div style="text-align: center;">  <p>中速前进</p> </div> <div style="text-align: center;">  <p>高速前进</p> </div> </div>
<p><b>音量调节:</b></p>	<p>可通过遥控器调整整个系统的声音大小。 也可以通过手机APP进行设置。系统音量默认为50%。</p>



## 电调说明

该产品支持有刷和无刷电调,支持最大电流为60A,可以在APP上选择电调支持模式即有刷模式或无刷模式,系统默认为无刷模式,两个模式切换后必须重启系统,才能生效切换后的模式。

### 警告

#### **注意无刷和有刷不能设置错误,否则有烧坏机器的风险!!!**

- 1、有刷电调使用B,C两条线(黄色和绿色),A相线(蓝色)悬空。
- 2、无刷电调可选择带霍尔或者不带霍尔模式,可在APP中选择(注意霍尔线和主线有对应关系,如果无法启动,需要交换主线的顺序,一共6种情况中只有一种是可以的,霍尔传感器只支持120度安装方式,霍尔供电电压4.9-7v电压)。
- 3、可在APP中设置电调功能的最大支持电流(依据电机实际支持的电流来设置)。
- 4、可在APP中设置无刷电调的速度控制模式,有普通模式和恒速模式,普通模式为输出功率依据油门位置决定,恒速模式为输出转速依据油门位置决定。(推荐使用普通模式)。
- 5、无刷电调无感模式下支持进角设定,范围为0-30度。推荐角度为25度,用户可依据电机实际情况进行微调。

## 输入通道(接遥控器)

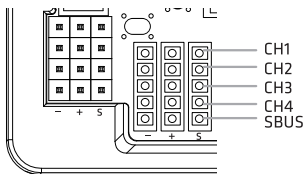

从上往下依次为CH1、CH2、CH3、CH4、SBUS/PPM通道

## SBUS/PPM多通道控制微调功能

当使用大于4通道的多功能遥控器时,可将其他通道设置为其他特殊功能(通过手机APP设置),不再需要使用微调等复杂操作。

注意需要根据遥控器实际通道的功能(有2档开关,3档开关,电位器)来合理选择功能。(比如音量控制推荐使用电位器通道来控制)。

注意,通道信号的优先级为SBUS(最多14通道)>PPM(最多8通道)>PWM(4通道)。当识别到高优先级的信号时,低优先级的信号自动失效。其中SBUS为输入的第五通道(专用)。PPM通道为原PWM通道的第一通道输入,1-4通道为原PWM通道输入。

## 输出通道(接舵机马达)

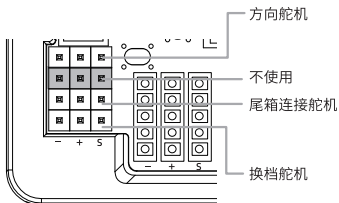

从上往下依次为: 方向舵机接口、空、尾箱连接器舵机、换挡舵机

备注:靠近最左侧为负极(接地),中间为正极,最右侧为信号线。

## 灯光控制模块

灯光控制中,可以选择自动、常亮、常闭三种状态,自动状态可以接受遥控控制,常亮或常闭不能接受遥控控制。

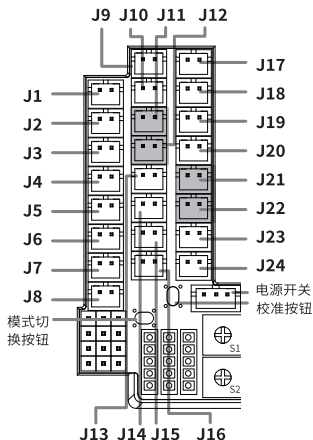

所有灯线都有序列号按照对应号码连接



套管的颜色代表灯的颜色

J1-J3:	速度灯1-3	Φ3	黄色
J4:	顶灯	Φ3-Φ3	黄色
J5:	雾灯	Φ5-Φ5	白色
J6:	货柜尾灯(左转向)	Φ3	黄色
J7:	货柜尾灯(右转向)	Φ3	黄色
J8:	拖头连接器		
J9:	刹车灯	Φ5-Φ5	红色
J10:	倒车灯	Φ3-Φ3	白色
J11/J12:	空	*	*
J13:	货柜无线尾灯	Φ5-Φ5	红色
J14/J15:	头灯2、头灯1	Φ5-Φ5	白色
J16:	空	*	*
J17:	前右转向灯	Φ3	黄色
J18:	后右转向灯	Φ5	黄色
J19:	前左转向灯	Φ3	黄色
J20:	后左转向灯	Φ5	黄色
J21/J22:	空	*	*
J23/J24:	前后辅助灯	Φ3-Φ3	白色

**J19**  
前左转向灯

**J5**  
雾灯

**J23**  
前辅助灯

**J15**  
头灯1

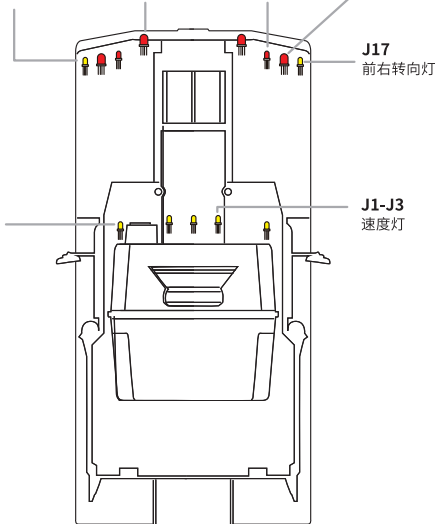

**J8**  
拖头连接器

**J20**  
后左转向灯

**J9**  
刹车灯

**J10**  
倒车灯

**J18**  
后右转向灯

**J24**  
后辅助灯

## 恢复出厂设置

**硬件恢复出厂设置:**在设备正常通电后5秒-20秒的范围之内,同时按主设置的两个按键(校准键和模式切换键)不放5秒以上,此时设备的所有LED快速闪烁,喇叭发出快速的滴滴滴声,然后放开按键,恢复出厂设置的全部内容包括:遥控器校准信息,舵机位置校准信息,手机APP设置内容,APP链接密码。

**手机端APP恢复出厂设置:**只恢复APP设置内容,其他的均不恢复。

## 下载APP

货柜车声光含有蓝牙模块,可通过蓝牙与手机链接,下载货柜车声光APP(扫描如上二维码下载APP),可以在APP上设置相关参数,通过APP控制所有模式及灯光,还可以使用手机遥控器,而且通过APP可以避免由于遥控器硬件区别导致不能触发的一些特定功能,通过手机轻而易举的就可以操作,具体如下图所示:

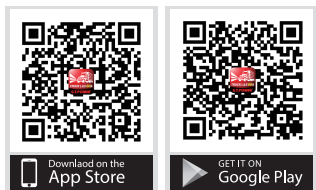

扫描二维码安装G.T.power货柜车  
声光系统专业版60A APP

**注意:**由于手机可以直接控制车辆,为了安全起见,APP连接新增密码功能,首次连接可以设置4位数的密码,在密码未修改的情况下,同一台手机只需要输入一次密码即可,如忘记密码,则使用主机恢复出厂设置,默认无密码。

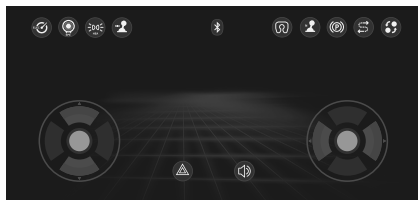

打开设置界面,选择“遥控器”选项,即可打开手机遥控,手机遥控功能详解



### 顶灯速度灯切换：

顶灯与速度灯切换，功能详情参考顶灯切换开关介绍。



### 驻车：

原地驻车



### 模式开关：

仿真模式和电调模式切换



### 转向舵机方向调整：

转向舵机反向调整



### 灯光切换：

关闭-顶灯-大灯-雾灯功能切换



### 手机遥控手柄方向切换：

下面遥控手柄方向垂直调整，即横向变纵向



### 磨盘拖钩：

一键分离拖头与货柜



### 危险报警：

开启危险报警灯(左右转向灯双闪烁)和报警声音



### 空挡：

原地空挡



### 喇叭：

打开或关闭汽笛声音



## • 第三通道功能

通过遥控器上第三通道可以选择喇叭开关功能或拖钩伺服器功能。

遥控器输入错误报警：遥控器输入错误时喇叭会报警同时APP首页会出现报警信号。



## • 电池电压过低保护

打开该功能，当电池每节电压低于3.3V时该系统自动关闭。

电调反向设置：可以对电调进行正向或者反向设置，然后对马达进行控制。



## • 自动启停

当你启动该系统后,如果当前油门中立,车辆静止,发动机处于怠速状态,开启了自动启停系统后,声音系统会根据你设定的时间(5S-60S),延时以后自动熄火,只有你再次触动油门时发动机才会重新启动,你也可以选择关闭,此时不管任何状态,只要发动机已经启动,声效系统一直处于工作状态。

**启动灵敏度:**通过设置启动灵敏度(0-100)来迅速或者正常启动发动机。

**电调空挡开关:**当打开该功能时,车辆不会前进,可以通过该功能来设置相关灯光及模式,关闭该功能,车辆可正常前进。

## SBUS/PPM设置

遥控器支持SBUS功能,且通道较多即可设置,包括主音量调整、电调力度调节、震动力度调节、双闪灯(危险报警信号)、灯光控制模式、原地熄火、电调空挡开关、第三通道磨盘脱钩喇叭切换、转向声切换、顶灯速度灯模式切换、主模式选择、无刷电调有感无感切换、无刷电调普通/恒速模式切换、泄气开关、喇叭声切换。

### • 振动调节:

调节振动马达的转速

### • 电调力度调节:

调节电调力度大小即电调输出能力大小



## 遥控器校准

初次使用本产品,需使用遥控器对产品进行校准,具体校准方法如下(以左手油门遥控为例)

每一个通道校准顺序依次为,中位位置、最大值位置、最小值位置,进行校准。每次校准成功都会短响滴一声,每个通道校准成功都会长滴一声,校准失败会滴滴滴三

声,校准完成自动退出。(系统默认板控第1和4通道向右打为最大,向左为最小,第2和3通道向上打为最大,向下为最小,如果自己设置反向,校准时候自动调整)

如下为校准示意图

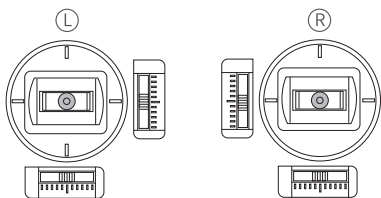

第1步:长按校准按钮,滴一声  
后方向通道(第1通道)确认中位,按下校准按钮,滴一声

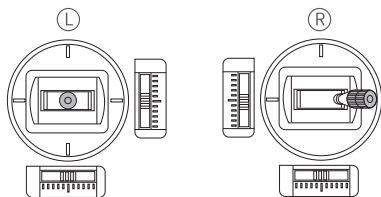

第2步:方向通道(第1通道)  
打到最大位置,按下校准按钮,滴一声

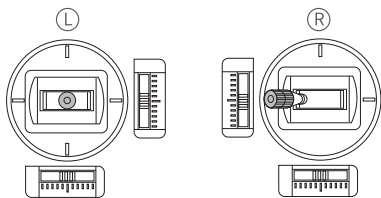

第3步:方向通道(第1通道)  
打到最最小位置,按下校准按钮,滴一声



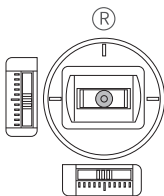
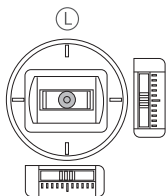

第4步:油门通道(第2通道)  
确认中位,按下校准按钮,滴一声

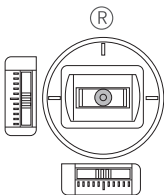
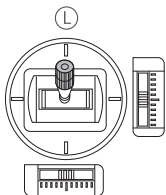

第5步:油门通道(第2通道)  
打到最大位置,按下校准按钮,滴一声

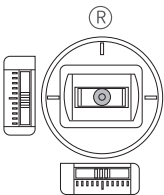
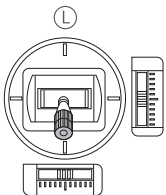

第6步:油门通道(第2通道)  
打到最小位置,按下校准按钮,滴一声

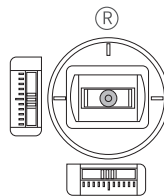
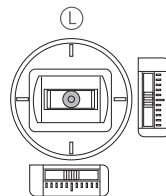

第7步:第3通道确认中位,按下校准按钮,滴一声

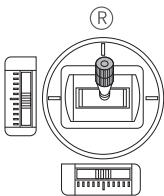
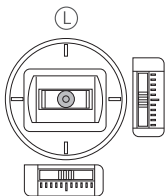

第8步:第3通道确认最大位置,按下校准按钮,滴一声

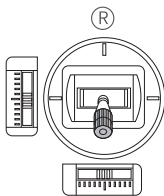
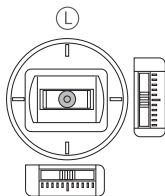

第9步:第3通道确认最小位置,按下校准按钮,滴一声

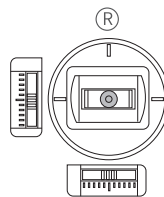
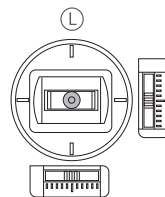

第10步:第4通道确认中位,按下校准按钮,滴一声

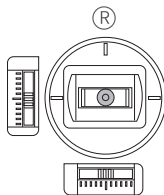
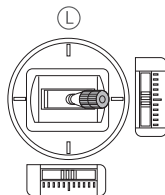

第11步:第4通道确认最大位置,按下校准按钮,滴一声

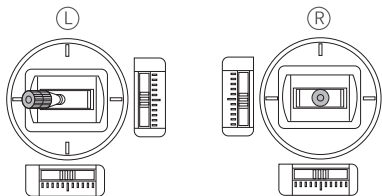

第12步:第4通道确认最小位置,按下校准按钮,滴一声校准完成,会有长笛一声,校准完成自动推出,校准失败会滴滴滴三声,请重新校准。

## 舵机位置校准

断开电源,将第一通道和第三通道保持最大值通电,会进入舵机位置校准模式。

此时将2个舵机(转向和换挡)插上电路板,分别控制S1和S2,则能控制换挡舵机和转向舵机的位置,将2个舵机的位置调至最佳,然后按动校准按钮,成功后会滴一声,失败则滴滴滴三声。校准2个舵机的

位置一共分为三步,分别为:调整S1和S2使舵机同时打到中位,按下校准按键;调整S1和S2使舵机通道同时打到最大值,按下校准按键;调整S1和S2使舵机通道同时打到最小值,按下校准按键;校准完成。

## 遥控器特殊控制方式介绍

### 1、灯光选择模式

遥控器发射机第3通道微调往下拨到底,然后遥控器第3通道往下拨,依次开启顶灯、大灯、雾灯和关闭。

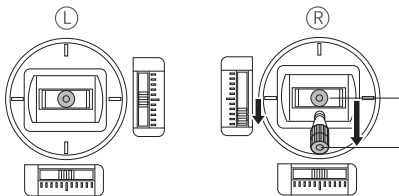

## 2、危险报警灯开启和关闭

遥控器发射机第3通道微调往上拨到底，然后遥控器第3通道往上拨到底，打开或关闭危险报警信号灯（左右转向灯同时闪烁）

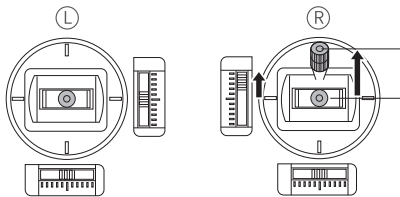

## 3、空挡模式

遥控器发射机第4通道微调往左拨到底，然后遥控器第4通道往左拨到底，开启或关闭空挡模式。

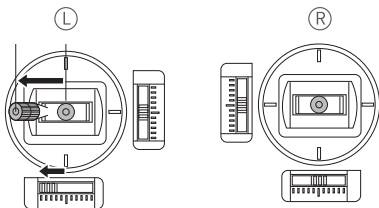

## 4、脱钩伺服器与喇叭开关切换

遥控器发射机第4通道微调往右拨到底，然后遥控器第4通道往右拨到底，切换第3通道功能，即脱钩伺服器与喇叭开关2种功能的切换开关。

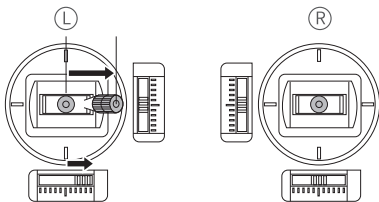

## 5、原地熄火

遥控器发射机第4通道微调往右拨到底，第3通道微调往上拨到底，然后遥控器第4通道往右拨，同时第3通道往上打，可实现原地熄火动作，如果需要再次启动，可重复操作打开一次，遥控器第3通道往下打，点火启动。或者关闭电源重新启动。

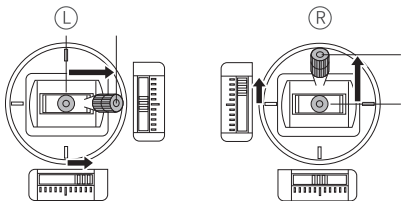

## 6、转向声音切换

第1通道微调向左打到底，第3通道微调向下打到底，即遥控器摇杆打向左下角，就可以切换转向声音。

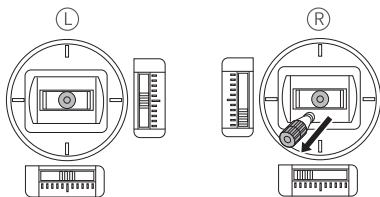

## 7、手动泄气

第三通道往下打，然后第二通道（油门）往下打会触发泄气声。

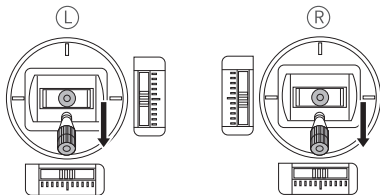

## 货柜无线尾灯系统(选购)

该系统可以搭配RC货柜无线尾灯系统,其采用无线红外技术,可以高效的操控,便捷连线,省去复杂繁琐的灯线连接,化繁为简。

### 使用方法:

如图所示的原刹车灯位置(专业版货柜车灯60A-J13位置)接口插入红外发射接头,现刹车灯插在尾灯系统刹车灯位置即可。

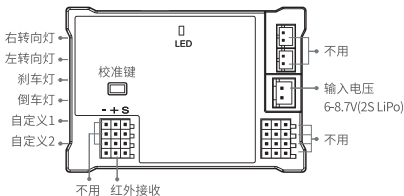

### 配对方法:

1、尾灯板上电,板上蓝色LED常亮,首次使用必须配对,配对方法:长按尾灯板按键直到蓝色LED闪烁,然后将专业版货柜车灯系统主板红外发射头插好并且对准红外接收头,尽量保持最近距离。

2、给专业版货柜车灯系统上电,等待几秒钟后尾灯板蓝色灯自动转为常亮则配对完成。如果更换主板或者尾灯板以后需要再次配对。

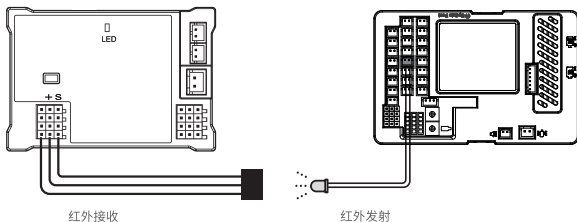

## 装配说明

1、安装主控盒、控制板、喇叭前请将其底部擦拭干净,用配带的3M胶片粘在您车上的合适位置(不同品牌不同款式车均可适用),也可以使用您自己粘性好的胶水粘牢。

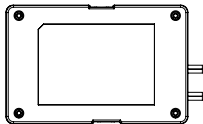

- 2、震动马达请按照图示进行组装及安装（4颗PA3.5\*8），注意安装甩块时，须使用螺丝胶进行辅助固定。因为振动量大，请确认固定好以防出现意外。

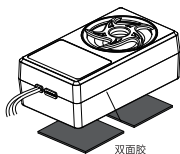
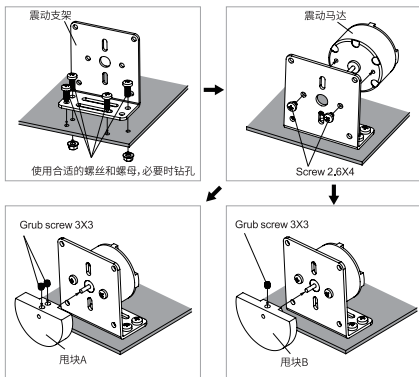

- 3、音效受到安装表面材料和尺寸的影响，应该在固定安装前选择最合适的位置。

## 参数

输入电压范围：	7-14V
灯组单组灯最大电流：	30mA
喇叭：	4欧阻抗，10W以上
遥控器：	必须使用4通道及以上
电调：	60A最大

## 产品清单

主控盒：	一个
振动马达：	一个
甩块：	两个
喇叭：	一个
灯线：	一套
说明书：	一份

## 保修说明

我们对您所购买的产品自购买之日起提供一年质保服务，此项服务只适用于产品质量问题。在产品质保期间，只要您凭借购买凭据，一切有质量问题的产品都可以免费维修或更换。但由于磨损，超负荷，进水，人为操作不当或者配件的错误使用造成的损坏则提供有偿维修服务。

# G.T.POWER<sup>®</sup>

